

V-989

使用手冊

Instruction Manual

使用前請閱讀此手冊
Please read this manual before operation



megaspin.net

使用前的注意事項 CARE BEFORE USE

發球機及集球網的各部位名稱	第 2 頁 page 2
Components name of the table tennis robot and ball collecting net	
集球網的安裝方法	第 3 頁 page 3
How to assemble the ball collecting net	
發球機的擺放位置	第 4 頁 page 4
How to position the table tennis robot	
使用電源	第 5 頁 page 5
What power supply to use	

發球機的功能介紹 INTRODUCTION TO FUNCTIONS OF THE TABLE TENNIS ROBOT

發球形式	第 5 頁 page 5
Ways to serve the ball	
速度調節	第 6 頁 page 6
Speed modulation	
頻率調節	第 6 頁 page 6
Frequency modulation	
旋轉選擇	第 7 頁 page 7
How to select spin	
角度調節	第 8 頁 page 8
Angle modulation	
任意點調節	第 9 頁 page 9
Random point modulation	
弧度調節	第 10 頁 page 10
Loop modulation	

注意事項與保養 CAUTIONS AND MA- INTENANCE

儲球器的容量	第 10 頁 page 10
Capacity of the ball Container	
發球機的保養	第 11 頁 page 11
How to maintain the table tennis robot	
故障的排除方法	第 13 頁 page 13
Trouble shooting	



發球機及集球網的各部位名稱
 Components name of the table tennis robot and ball collecting net



集球網的安裝方法

How to assemble the ball collecting net

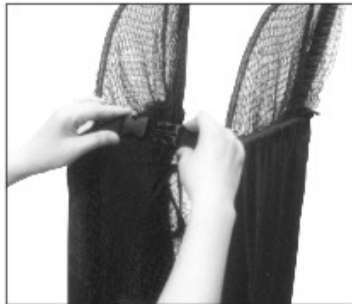

1、先將集球網的鎖扣打開。

First, open the lock buckles of the ball collecting net.



3、將集球網向兩邊推開。

Spread out the ball collecting net with both sides



2、將集球網略分開，網的方孔套進發球機的機頭。

然後集球網插銷插入發球機的支承架上。

Partially unfold the ball collecting net, adapt the square outlet of the net with the robot head.

Insert the pin in the ball collecting net into the support frame of the robot.

支承架
Support frame

4、將發球機移至球臺邊緣，移動時應把腳輪鎖緊器打開。

Put the table tennis robot close to the edge of table. Open the wheel lock when moving the robot.

鎖緊器
Wheel Lock



發球機的擺放位置

How to position the table tennis robot

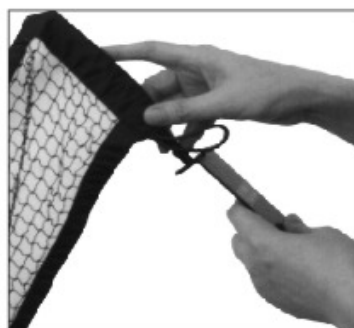

5、將集球網兩側的尾端套進網架上。

Put both end sleeves of the ball collecting net on the net supports.

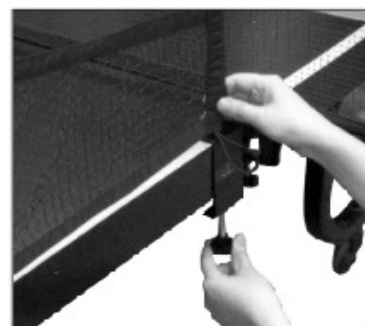

6、網架分別夾在球臺近球網的兩側。

The net supports are clamped to both sides of the table near the net.

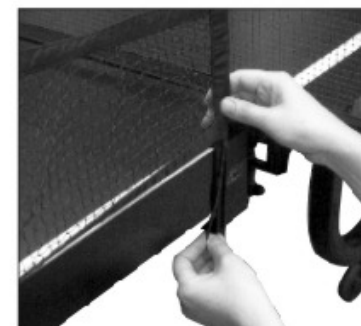

7、橡皮筋扣在網架的側邊。

And the rubber rings are to be buckled to the outsides of the net support.



The presenting picture of a completed installation
全部安裝完畢展示圖

8、訓練結束，將集球網按原來程序收疊，將鎖扣扣好，移放在任意位置。

After training, fold back the ball collecting net in a reverse order of the original process, lock the buckles in a right way, and put it in any suitable place.



使用電源 What power supply to use



發球機的適用電源在主機側面有標注，請選擇使用，電源插頭與插座要接觸良好，使用完畢則要撥開切斷電源。

The data of proper power source for robot is marked on the side of machine body, which may be selected and used optionally. The connection between plug and socket should be perfect. They must be pulled and separated completely after use.

發球形式 Ways to serve the ball

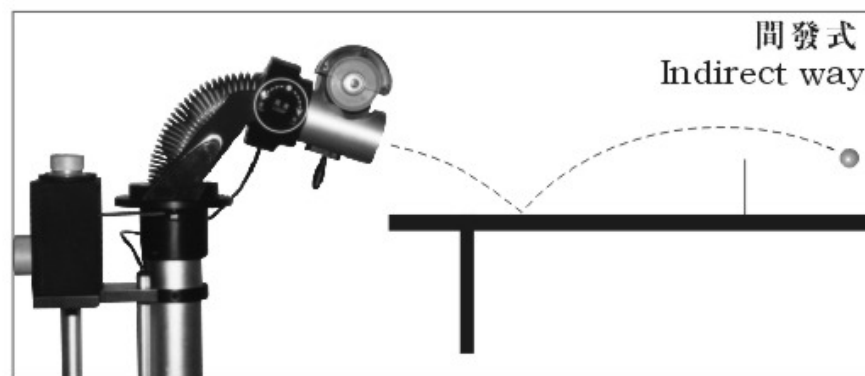
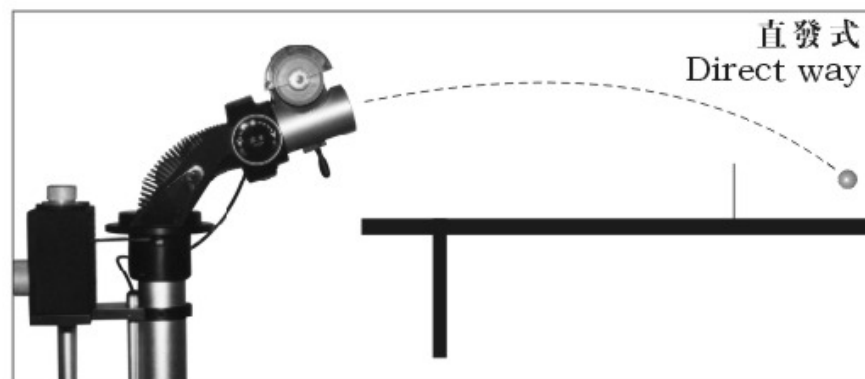

發球機的發球形式分為直發式和間發式，直發式發出的球速度和旋轉都比間發式稍強，調整時通過弧度調節旋鈕進行。

The ways of serving the balls consists in the direct way and indirect way. The speed and spin of the former will be stronger than those of the latter. They may be adjusted with the loop adjustment knob.

速度調節 Speed modulation

發球速度由控制盒的輕觸按鍵進行調節，共分9個檔位，顯示窗內顯示的“1”字是最慢檔，“9”字是最快檔，根據自己的要求隨意調節，另外，控制盒具備記憶功能，停機或切斷電源后重新開機時，速度與頻率都能保持在關機前的相同檔位。

Speed of balls served is adjusted with touch key on control box that has 9 stages. The digital "1" in the display is the lowest stage, "9" is the fastest stage. They can be adjusted optionally according to your requirement. On the other hand, control box has memory function. When restarted after stop or switch-off, it can keep the speed and frequency in the same stages as they have been before.

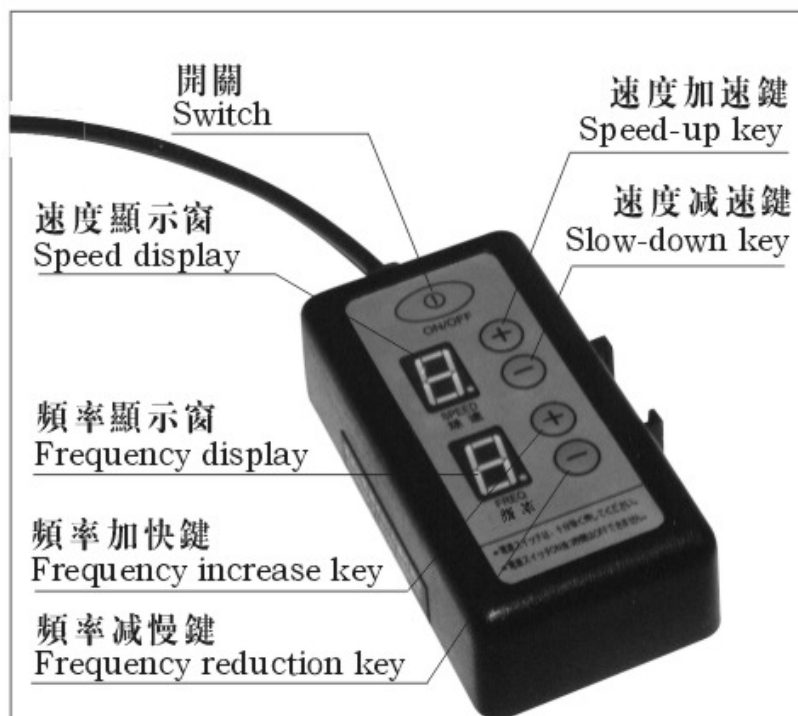

頻率調節 Frequency modulation

發球機的頻率也是通過控制盒的輕觸按鍵進行調節，同樣是9個檔位，顯示窗顯示“1”字時出球頻率最慢（每分鐘出球約30個），顯示“9”字時最快（每分鐘出球約85個）。

Frequency of balls served is also adjusted with touch key on control box that has 9 stages, too. The digital "1" in the display is the lowest stage (30 balls per minute), "9" is the fastest stage (85 balls per minute).

旋轉選擇 How to select spin

選擇旋轉的時候，按機頭上的指示牌，擺動機頭手柄，選擇所需的旋轉，對准三角形標點，機頭可正、反180度旋轉，調節時注意機頭電纜不能拉得太緊，以免拉斷。

When selecting the spin of ball, first rotate handle of motor head according to the instruction of the board on the motor head. And then, select the spin required, and aim it to the triangle mark. The motor head can be rotated in 180 degree. Please do not pull the wire too tight when rotating motor head, in order at the end to avoid the wire being broken.



角度調節 Angle modulation

發球機的出球角度由A旋鈕和角度調整旋鈕控制，A旋鈕控制出球的定點和兩點(最小角度的起點)，角度調整旋鈕是調整出球角度的大小，在調整時，先將A旋鈕的紅點調到“定點”位置，然後，根據銘牌的指示選擇好角度的大小，最後再把A旋鈕的紅點調回到“兩點”的位置上。

The angle, at which the robot shoots the ball out, is controlled by knob A and the angle modulation knob. For knob A controls fixed point to shoot the ball at and the alternative point (start point of a minimal angle) to shoot the ball with, while the angle modulation knob is to regulate the size of a certain angle for the ball to shoot out. When modulating, first turn knob A to move its red dot to the fixed point position. Then, select the size of an angle according to data in the nameplate. Finally, turn knob A with its red dot returning to the alternative point position.



任意點調節 random point modulation

當選擇出球任意點的時候，首先將A旋鈕的紅點調到“兩點”的位置（參閱第8頁），然后再將B旋鈕的紅點調到“任意點”的位置，這樣發球機出球就會是任意點。如果將B旋鈕的紅點調在“標準點”位置，這樣就會是有規律的兩點。



When choosing to make the ball shoot randomly, first turn knob A to move its red dot to the alternative course position (see page 8). Then turn knob B to move its red dot to the random point position. The robot will shoot the ball out randomly in this way. If turning the knob B to move its red dot to standard point position, the ball shooting position will back to regular alternative point position.

弧度調節 Loop modulation



調整出球弧度的高低時，首先用左手松開弧度鎖緊旋鈕，右手握住弧度調節旋鈕任意調整，達到自己所需的弧度后，將弧度鎖緊旋鈕鎖緊。

When modulating the loop of the serve, loosen the loop lock knob with your left hand, while adjusting the loop modulation wheel with your right hand. When achieving your desired loop, lock the knob.

儲球器的容量 Capacity of the Ball Container



儲球器裝40mm球約100個。放球時不能超過儲球器內側標籤所示黃綫位，不能將其它雜物也倒入儲球器內，否則會損壞機內零件，并影響發球機的正常工

The ball container may contain 100 balls in 40mm size. The level of the balls in the ball container should not be higher than the label (yellow line) positioned inside. Other things(except table tennis balls) should not be put into ball container, otherwise its parts may be damaged, affecting normal operation of robot.

發球機的保養

How to maintain the table tennis robot



電器部份：本產品的電器部分主要由主機線路板及控制盒組成，是發球機的指揮中心，所以盡可能避免受強烈震蕩，控制盒一定要按要求插在球臺邊的支架上，以免摔壞。任何液體都不能灑在上面，防止漏電及損壞內部的電子元件。

機械部份：發球機的機械部份主要集中在輸送球機構方面，特別注意的是除了乒乓球以外，任何雜物不能放入儲球器內，否則雜物會卡住發球機的輸送輪，造成不出球甚至損壞發球機，主機活動門下側安裝有方便觀察的視窗，如果發現有雜物，先打開活動門，拆下透明保護板，將雜物取出即可正常工作。儲球器內拔條使用長時間后，需檢查是否有螺絲鬆動或拔條斷裂等，以防止有下球不順暢故障發生。

Electric component: Electric component in this product consists mainly of the base machine's circuit boards and the control box, which is the command center of the table tennis robot. Therefore, it should avoid any strong oscillation as much as possible. The control box must be inserted to the support at the side of the table to avoid any dropping and breaking. Never spread any liquid to its surface, in order to prevent electric leakage and/or damage to its internal electronic units.

Mechanical component: Mechanical component in the table tennis robot is concentrated mainly on the mechanisms for ball service and delivery. Special attention should be paid that any foreign substances should not put into the ball container except for the balls. Otherwise, they would block the delivery wheel in the robot, and would result in no ball delivery and even make damage to the robot. There is a view window fixed at the under side of the movable door. So that you can open the movable door, remove the transparent guard plate, and take out any foreign objects if such things have entered, thus returning the robot to its normal operation. When the poke bar inside the ball container has worked for a long time, it should be checked for loose screws and/or broken poke bar, so as to prevent any trouble from happening which would lead to rough delivery of the balls.

集球網的安裝方法

How to assemble the ball collecting net



1、先將集球網的鎖扣打開。

First, open the lock buckles of the ball collecting net.



3、將集球網向兩邊推開。

Spread out the ball collecting net with both sides



2、將集球網略分開，網的方孔套進發球機的機頭。然後集球網插銷插入發球機的支承架上。

Partially unfold the ball collecting net, adapt the square outlet of the net with the robot head.

Insert the pin in the ball collecting net into the support frame of the robot.

支承架
Support frame

4、將發球機移至球檯邊緣，移動時應把腳輪鎖緊器打開。

Put the table tennis robot close to the edge of table. Open the wheel lock when moving the robot.

鎖緊器
Wheel Lock



發球機的保養

How to maintain the table tennis robot

正常情況摩擦輪能用5000小時以上，使用時間過長需要更換新的，更換時候，首先松開保護罩，用螺絲批取下摩擦輪的壓緊螺絲，順時針鎖緊，逆時針松開。

Under normal conditions, the friction wheel can work for 5000 hours or longer. However, the friction wheel should be replaced after over time use. When replacing, first of all, loosen the protective cover and take out the screw at the friction wheel with a screwdriver, which is to be tightened clockwise and to be loosened counter-clockwise.

發球機應保持清潔，摩擦輪使用時間長會有污垢，需用濕布抹掉，以保證出球的質量，另外各部位的旋鈕在使用過程中，調整力度要適當，不能粗暴強力操作，防止損壞內部零件。使用及運輸時需防止對發球機的強力撞擊或震蕩，練習結束後，電源插頭拔開切斷電源。

The table tennis robot should be kept clean. There would be some dirt in the friction wheel after a long time of operation. But such dirt can be wiped off with a wet rag, so as to ensure a quality shoot of the ball. Suitable strength should be used when turning the regulation knobs at the other places during an operation. Never do it with a rough or shock force, so as to prevent damage to the internal parts. During an operation and/or transportation, protect the table tennis robot against any strong impact or oscillation. Unplug and cut off the power supply when you have finished your exercise.

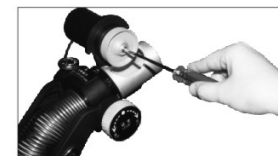

故障的排除方法 Trouble Shooting

故障 Failure	故障原因 Cause	排除方法 Solution
主機不工作 Machine doesn't work	<ul style="list-style-type: none"> ● 電源綫插頭與插座接觸不良 The plug and socket are not properly contacted ● 控制盒輕觸開關未按 The key on the control box is not pressed ● 控制盒因強烈震蕩而失靈 The control box doesn't work due to fierce shake 	<ul style="list-style-type: none"> ● 檢查電源插座 Check the electric socket ● 按下開關到顯示窗內數字亮 Press the switch until the number display ● 更換控制盒 Replace the control box
主機工作但不出球 Machine works, but does not release the table tennis balls	<ul style="list-style-type: none"> ● 儲球器內拔條鬆動 The poke bar in ball container is lax ● 有雜物堵塞輸球管道 The ball duct is jammed by foreign objects 	<ul style="list-style-type: none"> ● 鎖緊拔條 Fasten the poke bar ● 清除雜物(見第11頁中的機械部份) Clear away the foreign objects(see page 11)
速度、頻率失調 Speed and frequency cannot be adjusted	<ul style="list-style-type: none"> ● 控制盒內零件暫時失靈 The parts in control box do not work temporarily ● 連接電機的電綫鬆脫 The cable connecting to motor is loosen 	<ul style="list-style-type: none"> ● 斷開電源5秒后啓動 Start up again after shut-off for 5 Seconds ● 按原樣接駁 Connect it with the original method

本公司有權未經事先聲明對本手冊中的產品描述進行改進。
The company has the right to amend the description of products in this manual without any notice in advance.