

A32W PRO ROBOT



User Manual

Paddle Palace A32W Pro



- **Two throw wheels, for multiple spin options**
- **Multiple Oscillation Options**
- **Very durable, made with high quality materials**
- **Ball Recycling and Net Collection System**
- **Rolls easily from table for easy storage**
- **No-Jam, easy-feed engineering**

FREE shipping to contiguous USA!
FREE 120 Nittaku Super Training Balls

The Paddle Palace A23W Pro has many outstanding advanced robot features, but is offered at a very affordable price! Unlike other robots in this price range, it has two throw wheels controlled by two independent motors. This gives you great control over setting the variety and degree of spins including topspin, underspin, sidespin and no-spin. It includes an automatic ball recycle and net collection system. It has multiple oscillation options, and has convenient robot controls on the player's side of the table. The A23W Pro is high quality, sturdy, reliable. It comes ready to play with virtually no assembly required, and it rolls from storage to table for very quick setup/take-down.

User Manual

Table of Contents

- 4 Robot Components / Features
- 5 Robot Installation and Placement
- 5 How to Assemble the Ball Catch Net
- 6 Control Box Features
- 7 Setting the Ball Loop for Serve
- 7 Setting the Throw Wheel Speeds
- 7 Setting the Frequency
- 8 How to Select Spin / Top Wheel and Bottom Wheel
- 8 Loop Modulation
- 8 Angle Modulation (Angle of Serve)
- 9 How to Maintain Your New Robot
- 10 Quick Start - Step-By-Step Instructions for Setting Up Robot
- 10 General Warning/Safety Issues
- 10 Trouble-Shooting



User Manual

PADDLE PALACE A32W PRO ROBOT

Robot Components / Features

This manual has been written to help you enjoy and get the most out of your new Paddle Palace Robot. Take time to read these pages thoroughly and keep it handy for reference when using your robot.

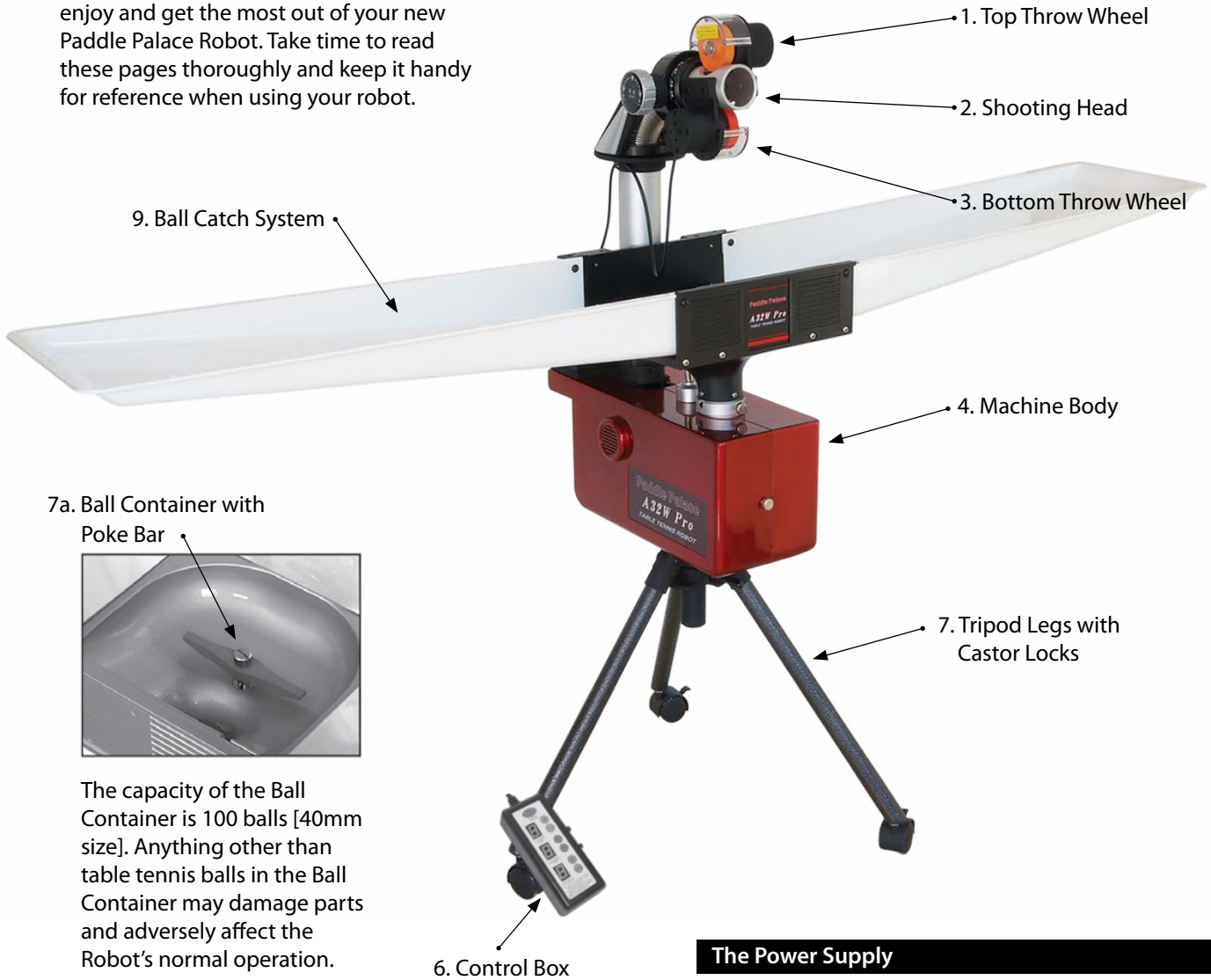

7a. Ball Container with Poke Bar

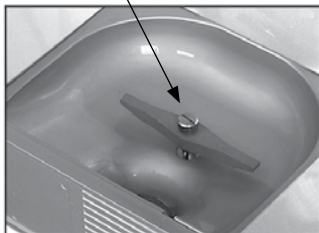

The capacity of the Ball Container is 100 balls [40mm size]. Anything other than table tennis balls in the Ball Container may damage parts and adversely affect the Robot's normal operation.

Net Hardware:

- A** 2 Net Supports that clamp on either side of table
- B** Control Box Support Bracket

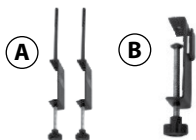

The Power Supply

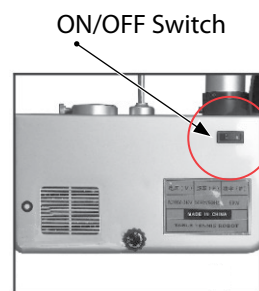

The Robot is powered by standard US home current (120V). Make sure the power cord is securely plugged in. The ON/OFF switch is located on the side of the Robot. Turn off and unplug the Robot when not in use.

User Manual

Robot Installation and Placement



The 3 basic components [at left] are Machine Body, Tripod, and Catch Net.

1. Lay the machine body down on its side. Insert the pin of the tripod into the bottom of the robot body. Lock with the knob.
2. Stand the Robot upright and rotate the safety ring to fixed position. Tighten the adjustable grip.
3. Insert the Catch Net into the machine.
4. Tighten Ball Catch Net knob.
5. Install Poke Bar inside the Ball Container and tighten knob.

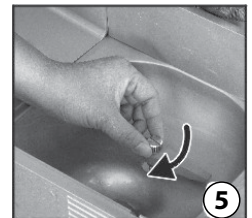

How to Assemble the Ball Catch Net



Be sure to open the Castor Lock while moving the Robot.

1. Unlock the buckle that holds the two halves of the Ball Catch Net together.
2. Open and spread out both sides of the net.
3. Pull out the round bar and insert it into the proper hole.
4. Put both end sleeves of the Ball Catch Net on the net supports.
5. Clamp the net support onto both sides of the table, close to the net.
6. Rubber rings are now buckled to the outsides of the net support.

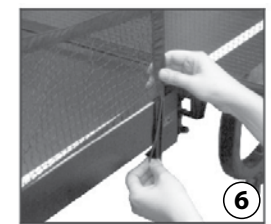
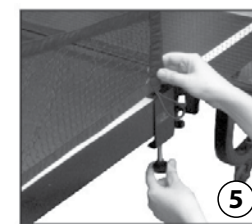
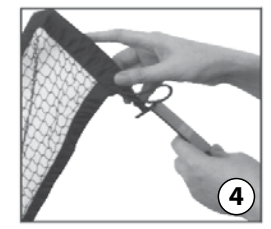
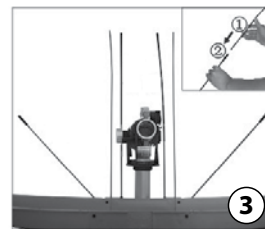
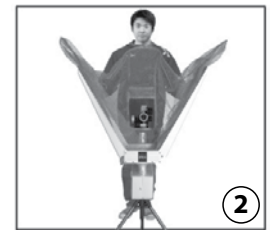
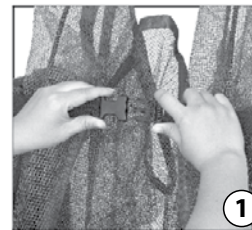

▲ Components are installed

Installation completed and robot is ready for play. ▶



NOTE: When practice is finished, unplug the Robot and fold the Ball Catch Net and fasten buckles to secure. Always take care when connecting/disconnecting Ball Catch Net and moving the Robot.

User Manual



A32W Control Box



User Manual

Setting the Ball Loop for Serve



The Robot can be set to serve the ball directly over the net or to bounce first on the server's side. A ball served directly over carries stronger spin and higher speed. Turning the Loop Adjustment Knob clockwise will result in the shooting pipe pointing higher, thus producing a ball that is served directly over the net. By turning the Loop Adjustment Knob counterclockwise, the shooting pipe will point downwards, producing a ball that bounces before going over the net. These adjustments can be made while the Robot is running.

Ball is set to serve directly over the net. ▶

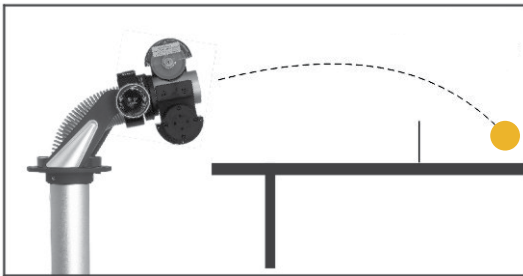

Ball bounces before going over the net. ▶

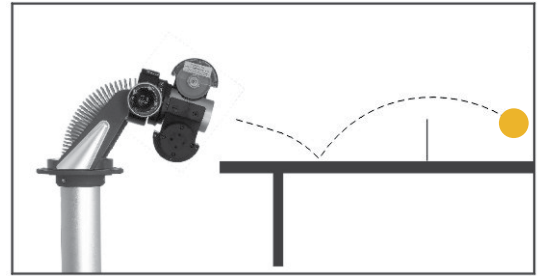

Setting the Throw Wheel Speeds (Amount of Speed/Spin)

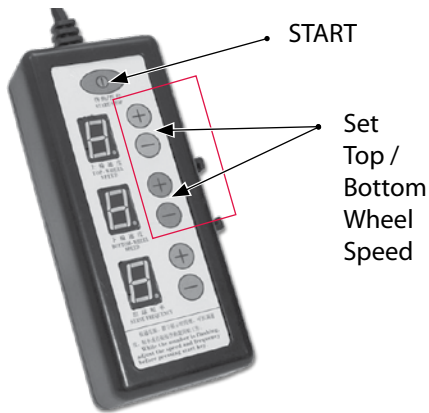

Wheel speed can be set in the working or standing mode. The top and bottom wheel display will blink the current settings when the robot is in the standby mode. The wheel speeds are changed by pressing the increase or decrease buttons. The speed of the top and bottom throw wheels determine the speed and amount of spin, or lack of spin of the ball delivered. Each wheel has 10 numeric settings. The higher the setting the faster the ball speed becomes. The ball speed is roughly proportional to the strength of spin.

To produce **topspin**, the top wheel is set at a higher number than the bottom wheel.

To produce **underspin**, the bottom wheel is set higher than the top.

Less or no spin is produced when the wheel speeds are set closely together.

Setting the Frequency

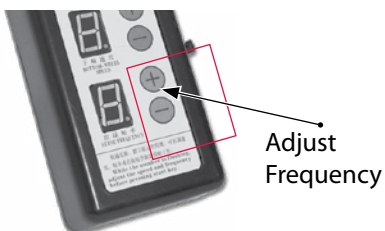

The ball frequency can be adjusted in the standby or working mode. Press the frequency "+" button to increase or "-" to decrease frequency.

There are 10 possible settings. The slowest (1) produces around 30 balls per minute. The fastest setting (10) produces around 85 balls per minute.

User Manual

How to Select Spin / Top Wheel and Bottom Wheel



Spin can be selected by adjusting both the speed of the Top Wheel and Bottom Wheel and by rotating the motor head of the Robot. There are 9 different spins to choose from:

- Top Spin
- Under Spin
- No Spin [produced by varying the speed of top and bottom wheel]
- Left Side Spin
- Right Side Spin
- Left Side Topspin
- Left Side Underspin
- Right Side Topspin
- Right Side Underspin

Loop Modulation

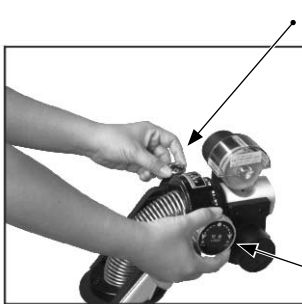

Loop Lock

When modulating the loop of the serve, loosen the Loop Lock Knob with your left hand, while adjusting the Loop Modulation Wheel with your right hand. When the desired setting is achieved, lock the knob.

Loop Modulation Wheel

Angle Modulation (Angle of Serve)

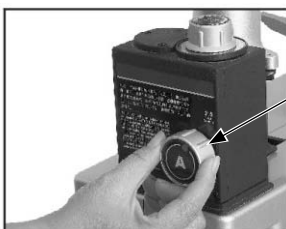

Knob A

Knob A and Angle Knob control the Robot's angle of serve. Knob A gives the option of either a fixed course or alternative course of serve. Angle Knob controls the size of the angle or the range of width of the serve.

There are 3 steps for setting the angle:

1. Turn Knob A and aim its red dot to a fixed point position.
2. Rotate the Angle Knob to the desired angle, using the indication label.
3. Turn Knob A back to the alternative point position.



Angle Knob

User Manual

How to Maintain Your New Robot

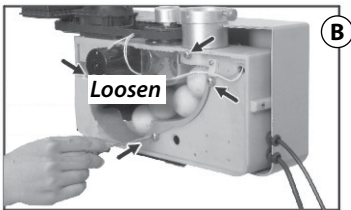
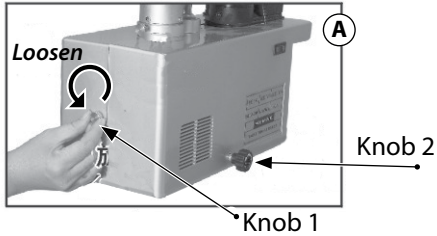

Using screwdriver, loosen the 4 screws (indicated by arrows).

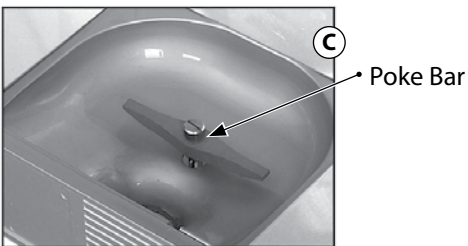

- **ELECTRONICS:** The robot's electric components are located in the machine's circuit board and the control box. Therefore, you should be careful to avoid dropping either component or avoid any activity that would cause damage to the internal electronic units of one or both of these components.

- **MECHANICS:** The robot's mechanical components are located in the mechanisms that produce the ball service and delivery. Special attention should be paid so that no foreign objects are put into the ball container. Foreign objects will block the robot's delivery wheel and result in damage to the robot. If a foreign object does enter the ball container, first, turn off the power, then loosen Knob 1 and Knob 2 (A). Open the movable door and remove the transparent guard plate (B). After removing the foreign object or objects, replace the guard plate and close the door and tighten Knobs 1 and 2.

- **POKE BAR:** When the poke bar (C) inside the ball container has worked for a long time, it should be checked for loose screws so as to prevent any trouble that would lead to an irregular ball delivery. This should prevent any blockage issue inside the robot.

- **FRICION WHEELS:** Under normal operation, and after long use, the top and bottom friction wheels may become dirty. To ensure a quality serve, please clean the wheels often with a wet towel (D). Always turn off the robot's power before cleaning. To avoid doing damage to the internal parts of the robot do not use force to move the shooting head.

The friction wheels are able to work for 5,000 hours or longer before they need to be replaced. When performing the replacement,

power off the robot, remove the protective cover and remove the screws from the friction wheels with a screwdriver (E) and (F).

Turn clockwise to tighten and turn counterclockwise to loosen. After replacing the wheels, replace the screws properly and with care.

During an operation or transportation, protect the robot against any strong impact or oscillation.

User Manual

QUICK START - Step-By-Step Instructions for Setting Up Robot

1. Set the **FREQUENCY** - Press (+) to increase. Press (-) to decrease.
2. Set the **HEAD ANGLE (LOOP)**.
3. Set the type of **SPIN**.
4. Set the **THROW WHEEL SPIN** (amount of speed and spin).
5. Press the **START/PAUSE** button to start the Robot.

General Warnings

1. Please read the instruction manual carefully before using the robot, and follow the operation instructions.
2. Use care when connecting and disconnecting the ball collection net.
3. When the robot is operating, please do not open the movable door and touch the top and bottom wheel. Do not touch the poke bar.
4. Turn the power switch off and unplug the robot after use.

Trouble-Shooting

FAILURE	CAUSE	SOLUTION
Robot doesn't work	The plug is not connected properly to the electrical outlet.	Check the plug connected to the electrical outlet
	The key on the control box is not pressed.	Press the switch until the number displays
	The control box doesn't work	Replace control box
Robot works but does not release the balls	The poke bar in ball container is loose	Fasten the poke bar
	The ball duct is jammed by foreign object	Clear away the foreign object (see page 9)
	The amount of balls in the container are not enough	The amount should be 50 to 100 balls
	It takes time to transport the balls from container to shooting head	Wait for a while
Speed and Frequency cannot be adjusted	The robot doesn't work due to the improper operation of control box	Turn power off. Wait 5 seconds, then start up again
	The cable connecting to motor is loose	Connect it with the original method
	Rechargeable battery has run out [if you are using a battery]	Recharge the battery until it reaches full charge